

# Life-Cycle Initiative:

A Joint UNEP/ SETAC Partnership to  
Advance the Life-Cycle Economy

James A. Fava, Ph.D.  
Five Winds International  
SETAC Representative

CP7  
Prague, Czech Republic  
April 28-30, 2002

Life Cycle



Initiative



Five Winds INTERNATIONAL

# Presentation Overview

- Who is SETAC
- Examples – illustrating value of a life cycle perspective
- UNEP/SETAC Life-Cycle Initiative
- How to become involved
- Point of contact

*Good for the environment  
- Good for business!*



# SETAC brings over 10 years experience in life cycle - [www.setac.org](http://www.setac.org)



- Society of Environmental Toxicology and Chemistry founded in 1979
- Over 5000 members worldwide – members from government, industry, academic and NGO sectors
- Recognized leader in scientific development and application of life-cycle assessment – will continue that role in Initiative
- Published over 10 books and reports on state-of-the-practice in field of life-cycle assessment
- Regularly holds life cycle symposiums and workshops
- Brings proven procedures for holding workshops & engaging shareholders



3M's product development teams use a Life Cycle Management matrix to systematically address the environmental, health and safety opportunities and issues



## Life Cycle Management Process

Life Cycle Stage \ Impact	Material Acquisition	R&D Operations	Manufacturing Operations	Customer Needs	
				Use	Diaposal
Environment					
Energy / Resources					
Health					
Safety					



See JP Fretiere; 3M - LCM 2001 presentation



Up to 80 % of product life cycle costs are determined in the design stage - although the actual costs occur downstream

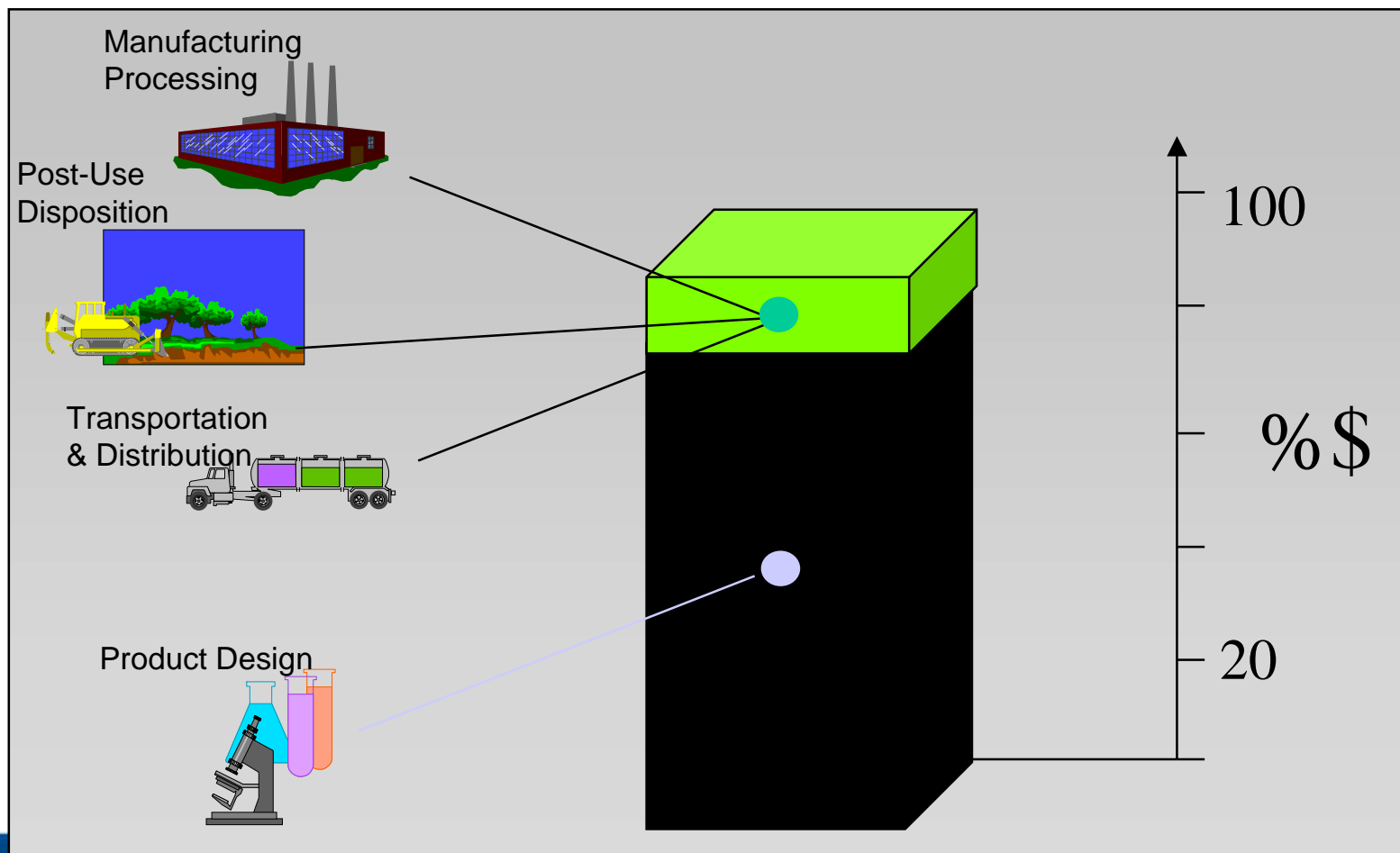

# New York City Transit (NYCT) is greening its supply chain

1. Purchasing of "greener" products/services
2. Environmental management systems
3. Reduced total cost of ownership

## The Best Choice is Not Always Obvious

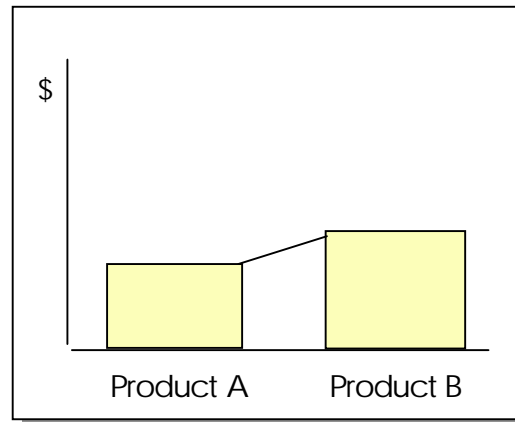

If only purchase costs are considered, Product A seems like the better choice.

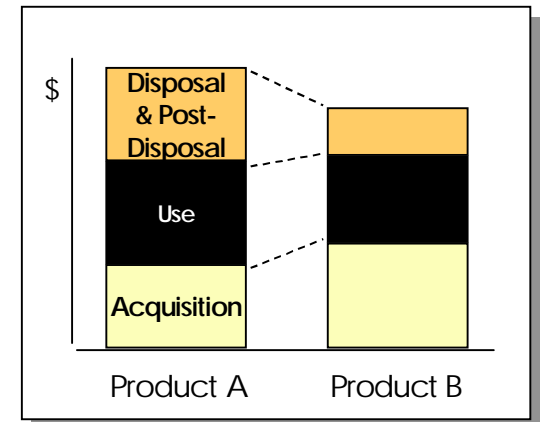

In the long run, Product B is more cost-effective.



## Objective of the Life-Cycle Initiative

---

*"Develop and disseminate practical tools for evaluating the opportunities, risks, and trade-offs, associated with products over their whole life cycle."*

-----

Our aim is

*"The enhancement of the application of LCA and Life Cycle Thinking in management practice"*



## The specific aims are:

---

- ▶ Aim 1: Exchange of information on the conditions for successful application of LCA and LC Thinking
- ▶ Aim 2: Exchange of information about the interface between LCA and other tools
- ▶ Aim 3: Implementation of educational activities related to the application of LCA and LC Thinking
- ▶ Aim 4: Enhancement of the availability of sound LCA data and methods
- ▶ Aim 5: Provision of guidance on the use of LCA data and methods



## The programs are:

---

- ▶ Program 1: the application of an education on LCA and LC Thinking (LCM program) (aim 1, 2 and 3)
- ▶ Program 2: the enhancement of sound LCI data and methods (LCI program) (aim 4 and 5)
- ▶ Program 3: the enhancement of sound LCIA data and methods (LCIA program) (aim 4 and 5)



# The UNEP/SETAC Life-Cycle Initiative

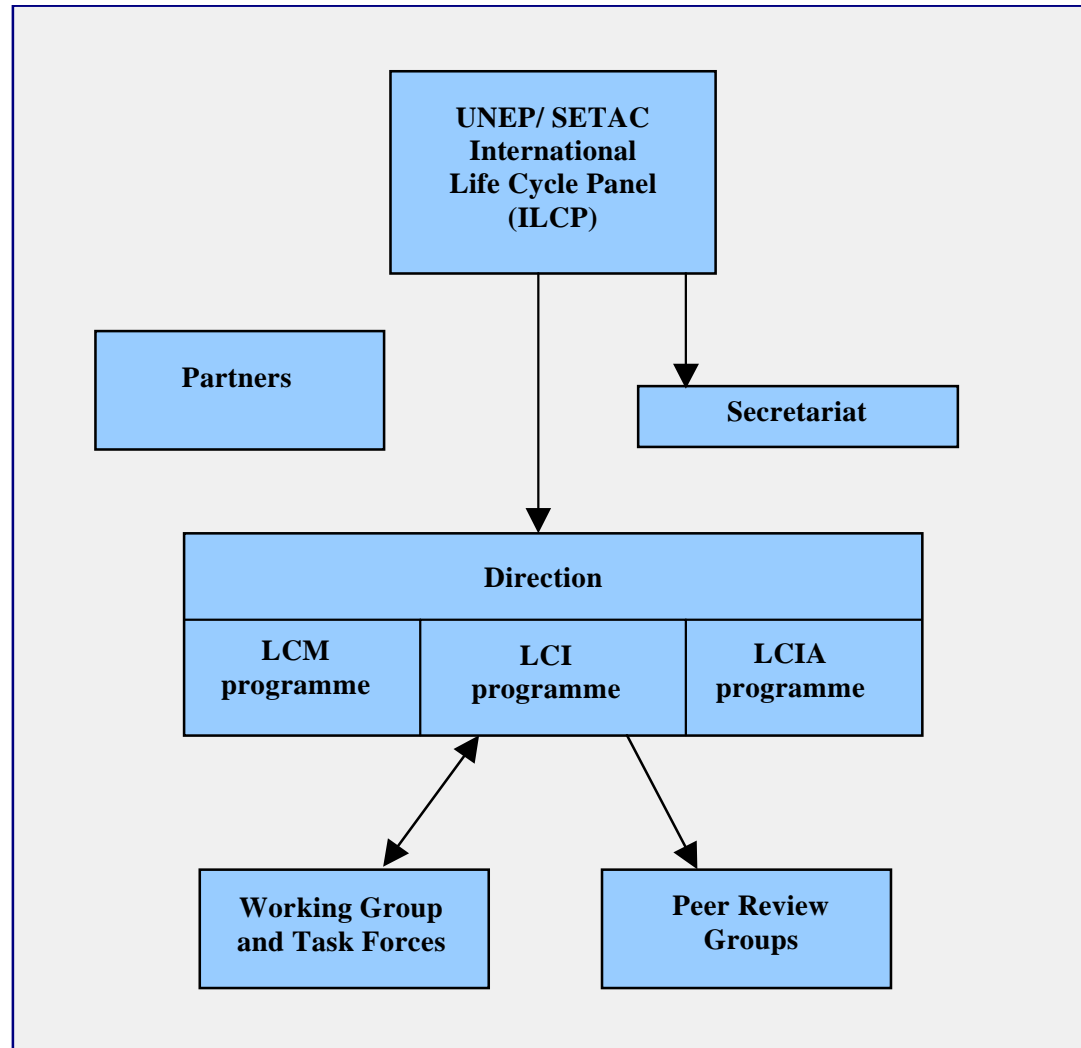

Your support is valuable



Interested in supporting and participating in the UNEP/SETAC Life-Cycle Initiative, please contact:

**For more information please contact:**

United Nations Environment Programme  
Division of Technology, Industry & Economics  
Production and Consumption Unit

39-43 Quai André Citroën

75739 Paris, Cedex 15, France

Tel: +33 1 4437 1450 Fax: +33 1 4437 1474

E-mail: [sc@unep.fr](mailto:sc@unep.fr)

<http://www.uneptie.org/sustain/lca/lca.htm>



Lets move together along this journey  
towards a life-cycle economy

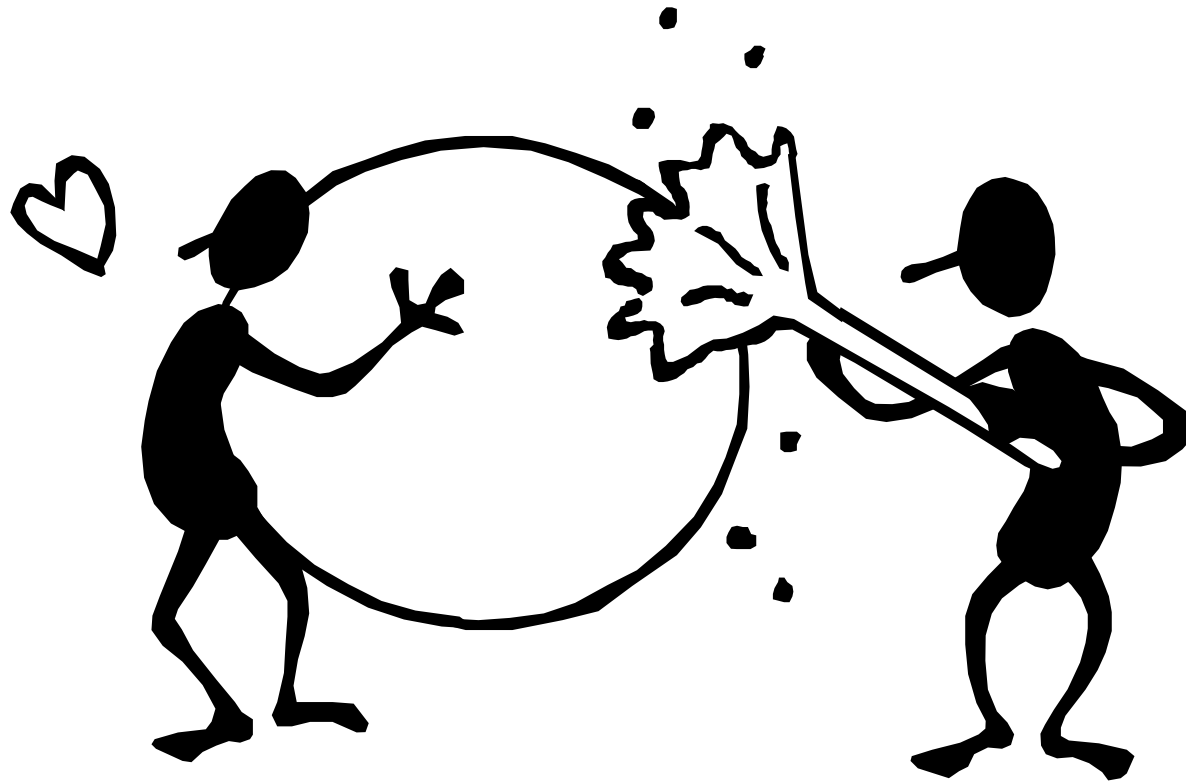

Thank you very much for your kind attention!

