

Life Cycle Inventory of Carpet Products

**Yong Li¹, Evan Griffing¹, Michael Overcash¹, and
Matthew Realff²**

1 North Carolina State University, Department of Chemical & Biomolecular Engineering

2 Georgia Institute of Technology, School of Chemical & Biomolecular Engineering

Environmental Facts Associated With Carpet Product

- **Textiles and carpets represent about 2% by weight of all municipal solid waste. Rate is higher based on volume.**
- **Roughly 4 billion pounds of carpet are disposed of in US each year.**
- **Most carpet and textile waste is landfilled.**

Environmental Studies of Carpet Product

- **Carpet recycling¹.**
- **Indoor air quality in carpet floor environment ^{2,3,4}.**
 - **Dust mite allergens**
 - **Cockroach allergens**
 - **Cat allergens**
 - **Carpet fungi**

1. M.J. realff, J.C. Ammons, and D. Newton, Polym.-Plast. Technol. Eng., 38(3), 547-567 (1999)
2. J.C. Stadler and G.L. Kennedy, Jr. Food Chem. Toxicol., 34, 1125-1130 (1996).
3. M.A. Berry, AATCC Review, 4(2), 22-25 (2004)
4. S. Causer, C. Shorter , and J. Sercombe , J Occup Environ Hyg 3 (4), 161-168, 2006

Motivation

Environment studies of carpet products have been mainly focused on recycling and indoor air quality issues. A systematic study is needed to fully understand the environment footprint of carpet products. By studying the life cycle of carpet products, we will be able to compare different carpet products, recognize the improvement potentials, and make valuable suggestions to carpet use and production.

Methodology to Obtain LCI Data

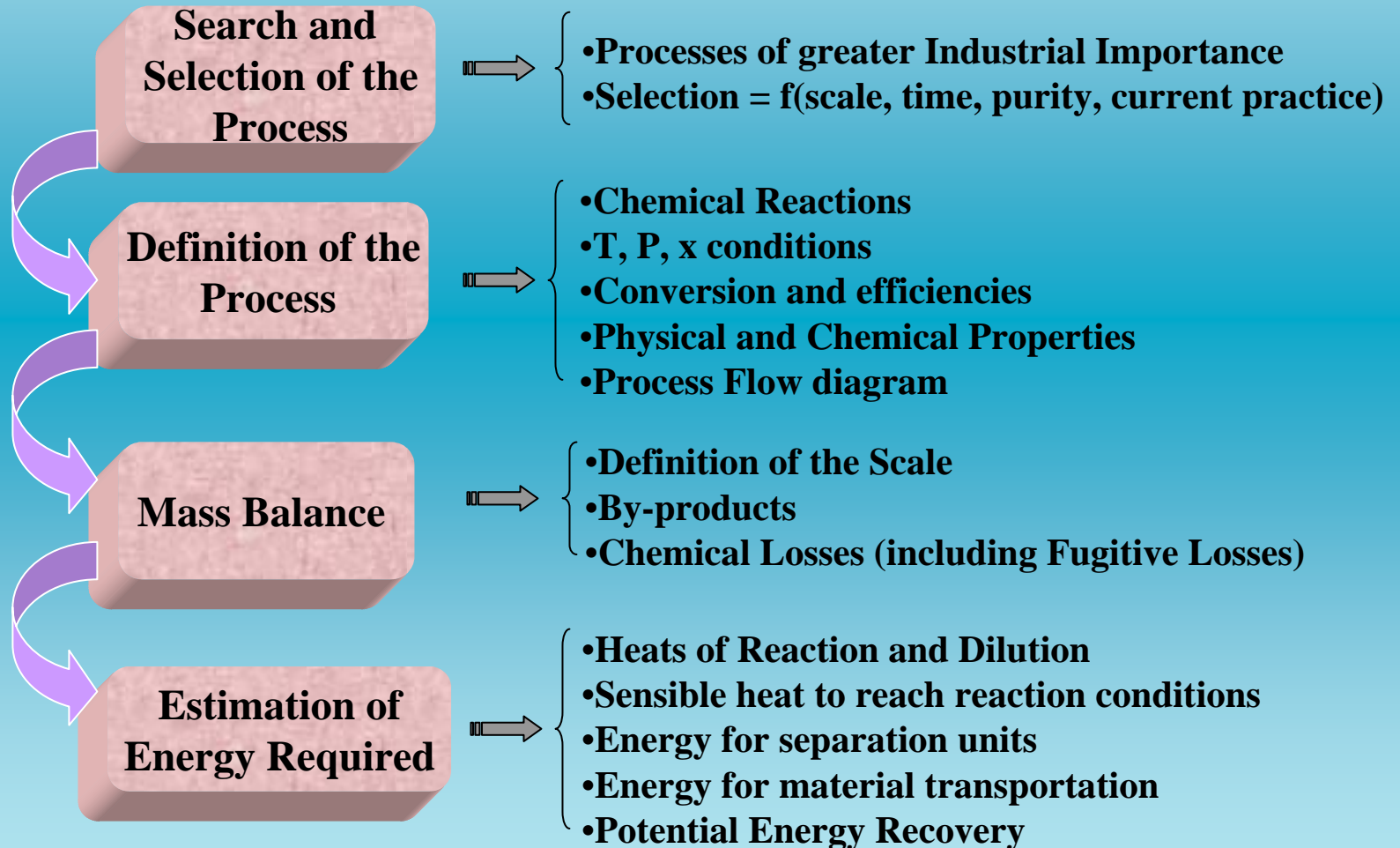

III. Representative Carpet Products

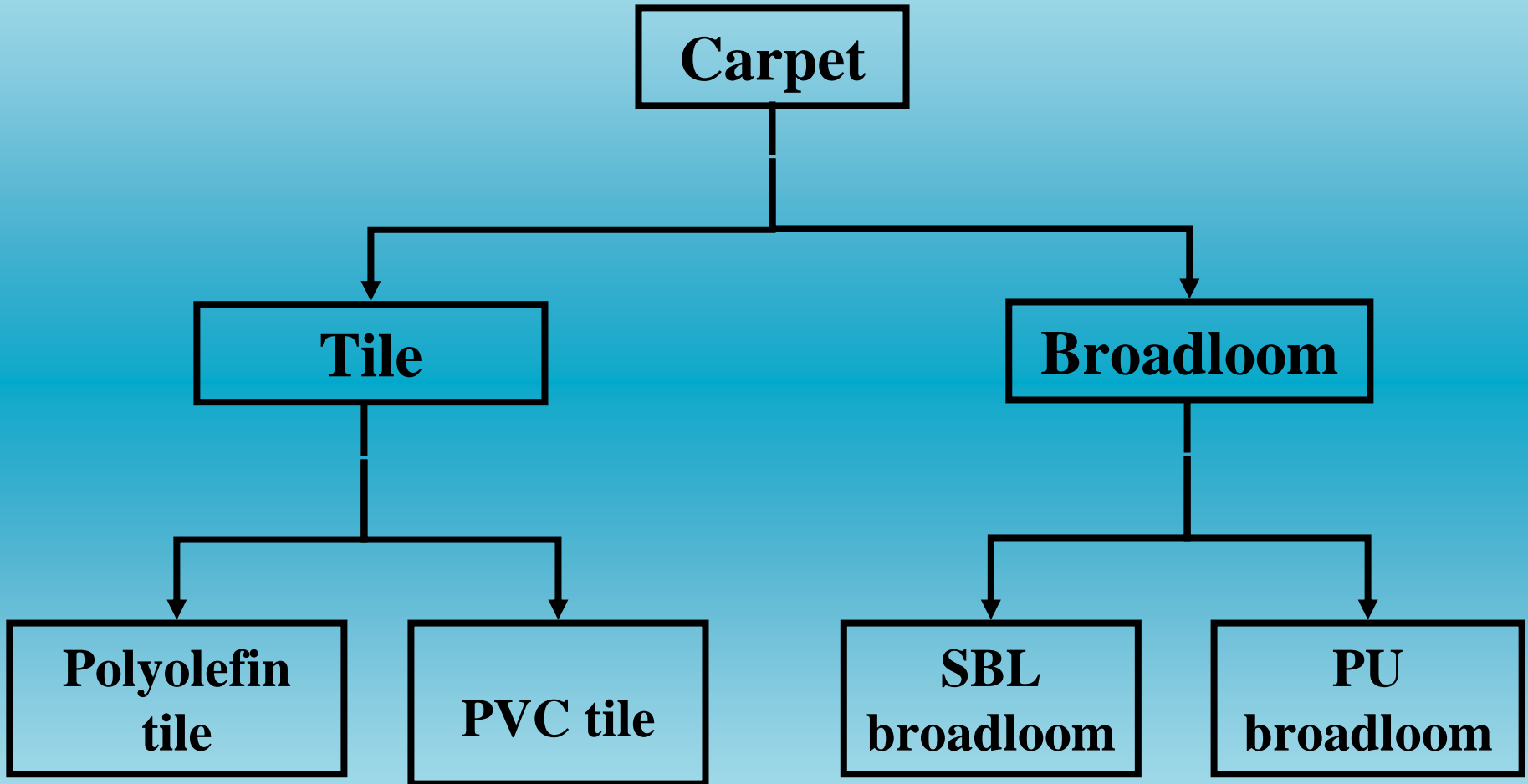

Tufted Carpet Structure

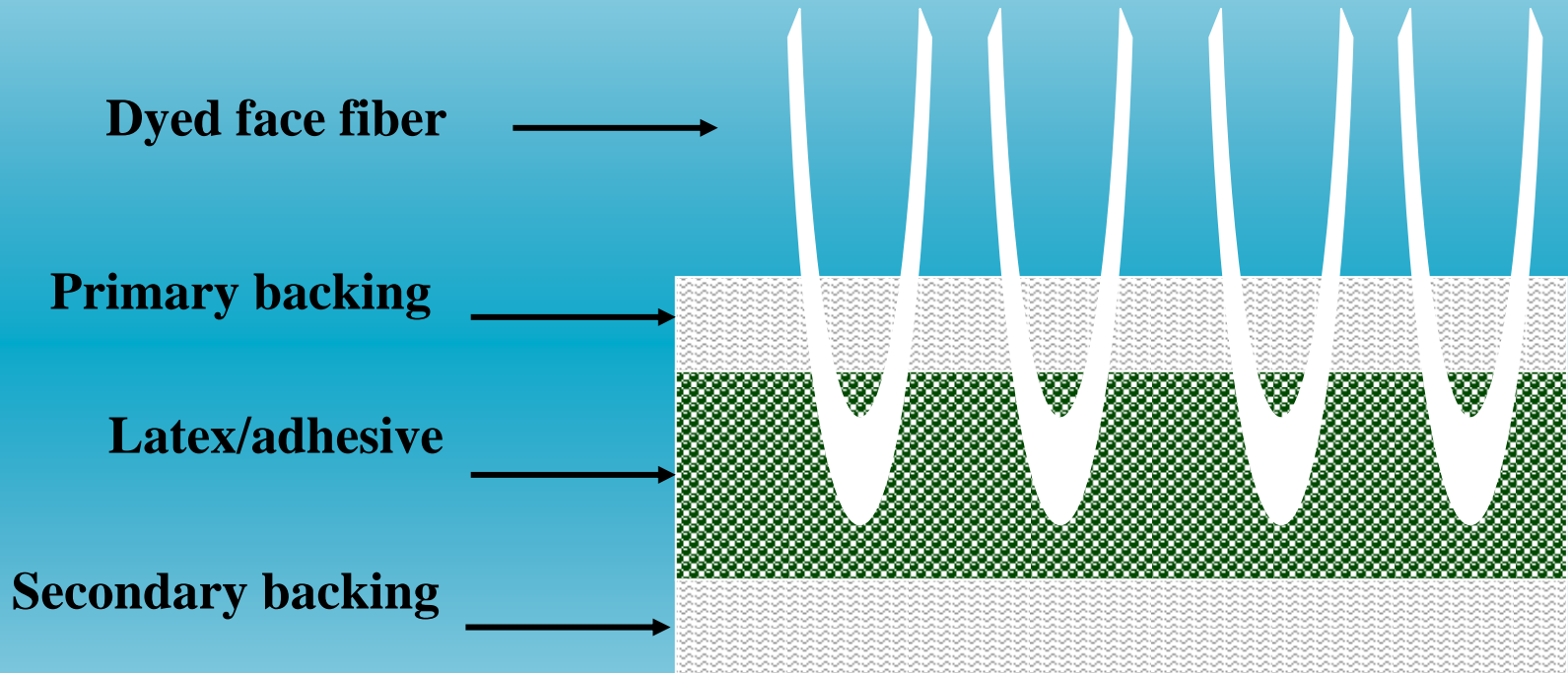

Carpet product composition

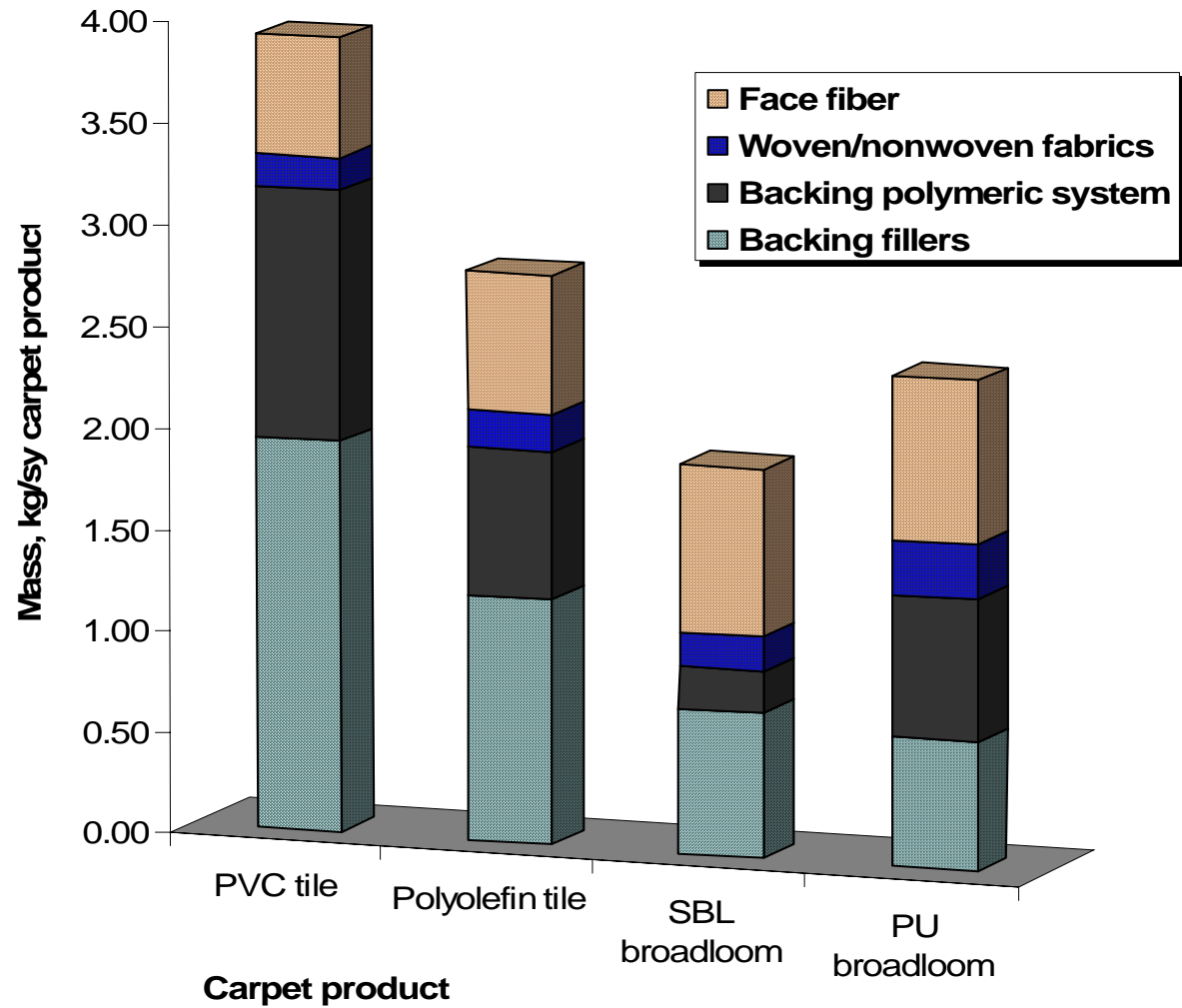

Life Cycle of Carpet Products

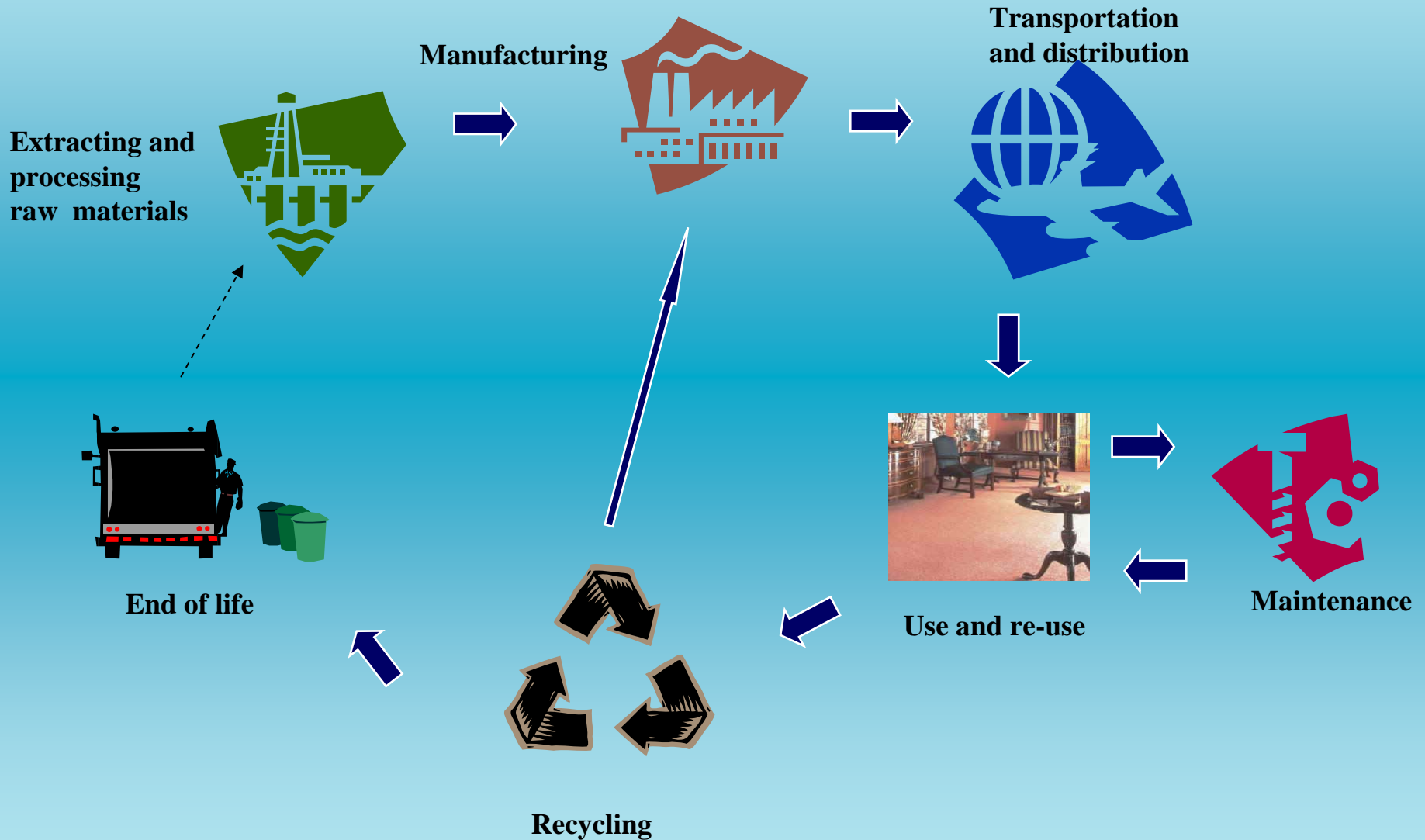

Major Steps of Carpet Manufacturing Process

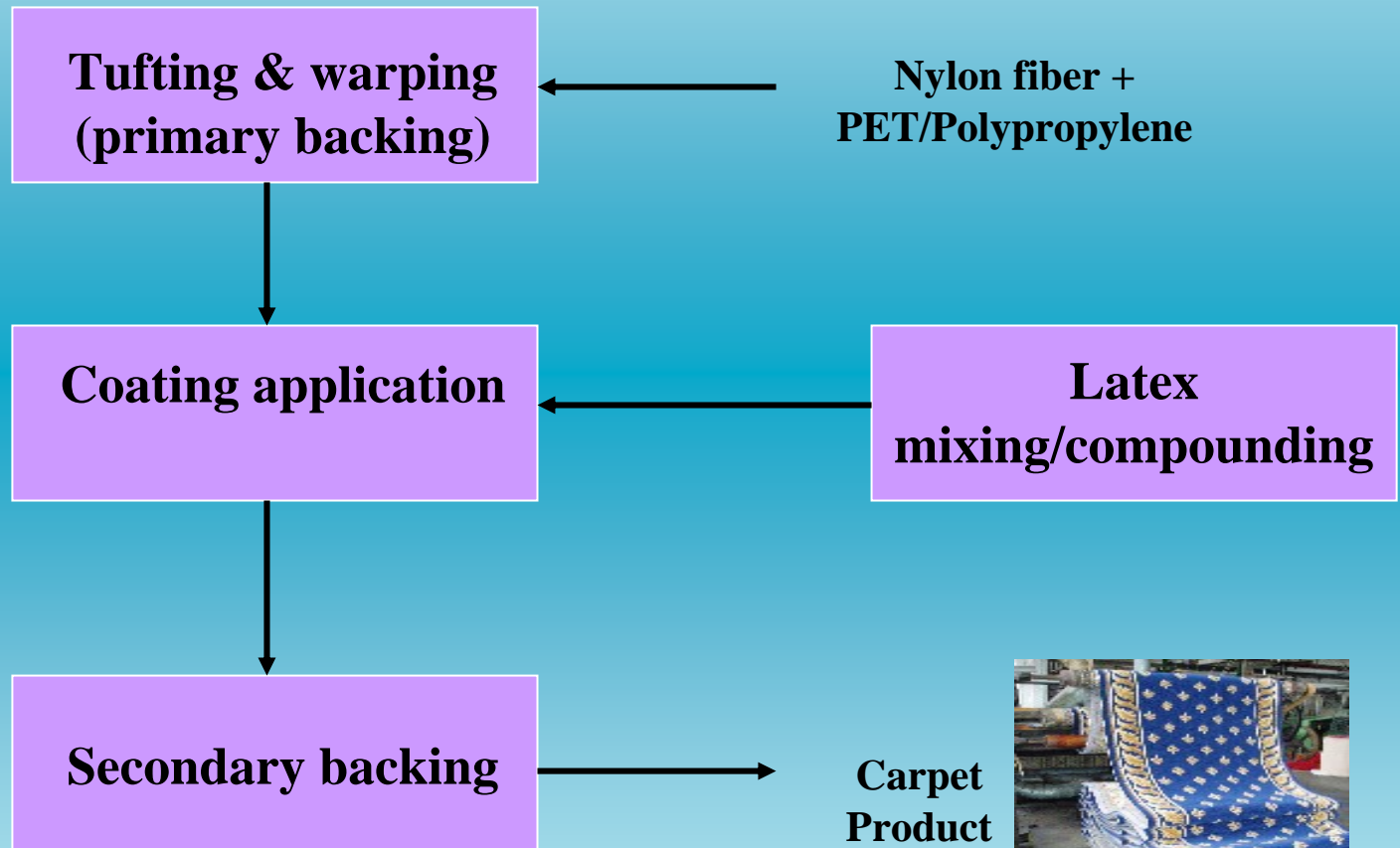

Detailed Process Flow Diagram of Polyolefin Tile Manufacturing Process- Page 1

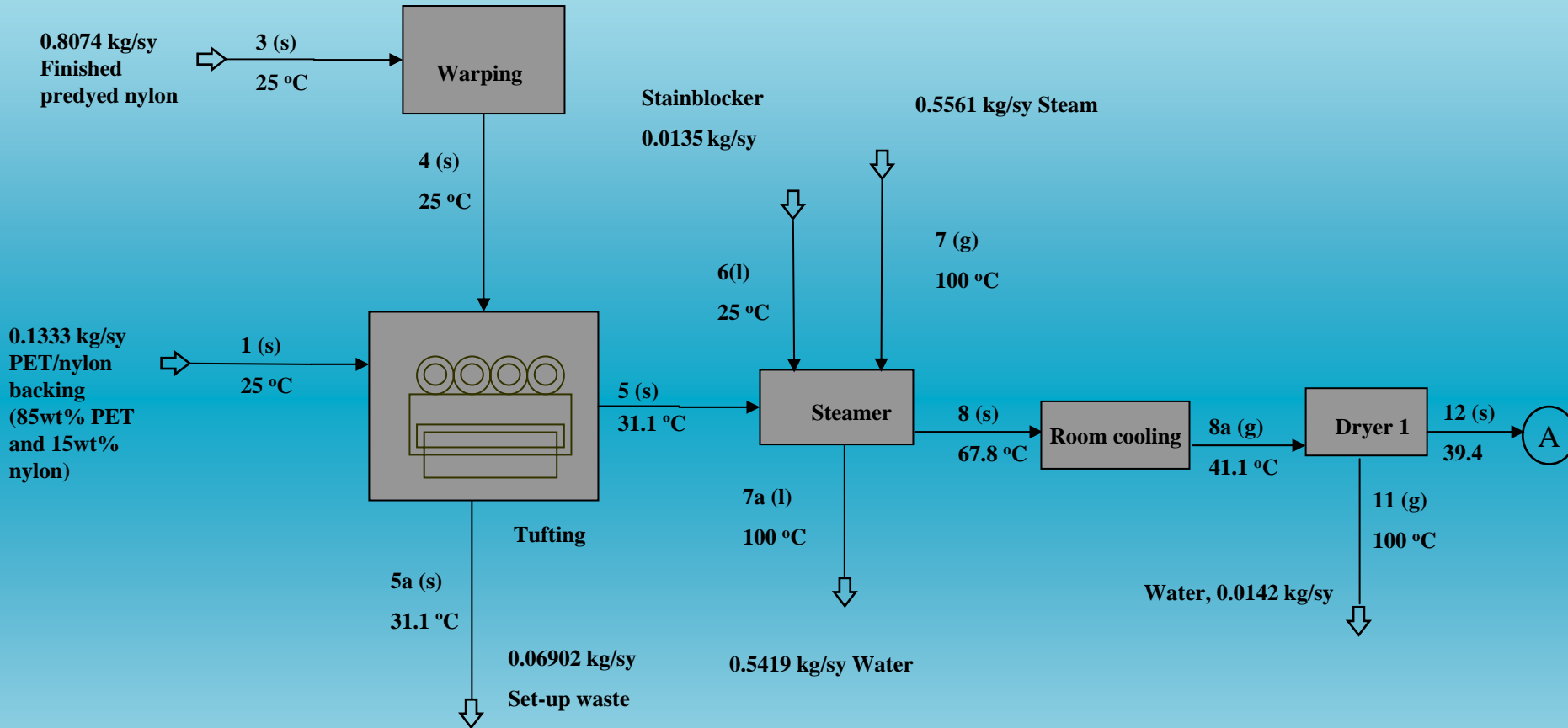

Detailed Process Flow Diagram of Polyolefin Tile Manufacturing Process- Page 2

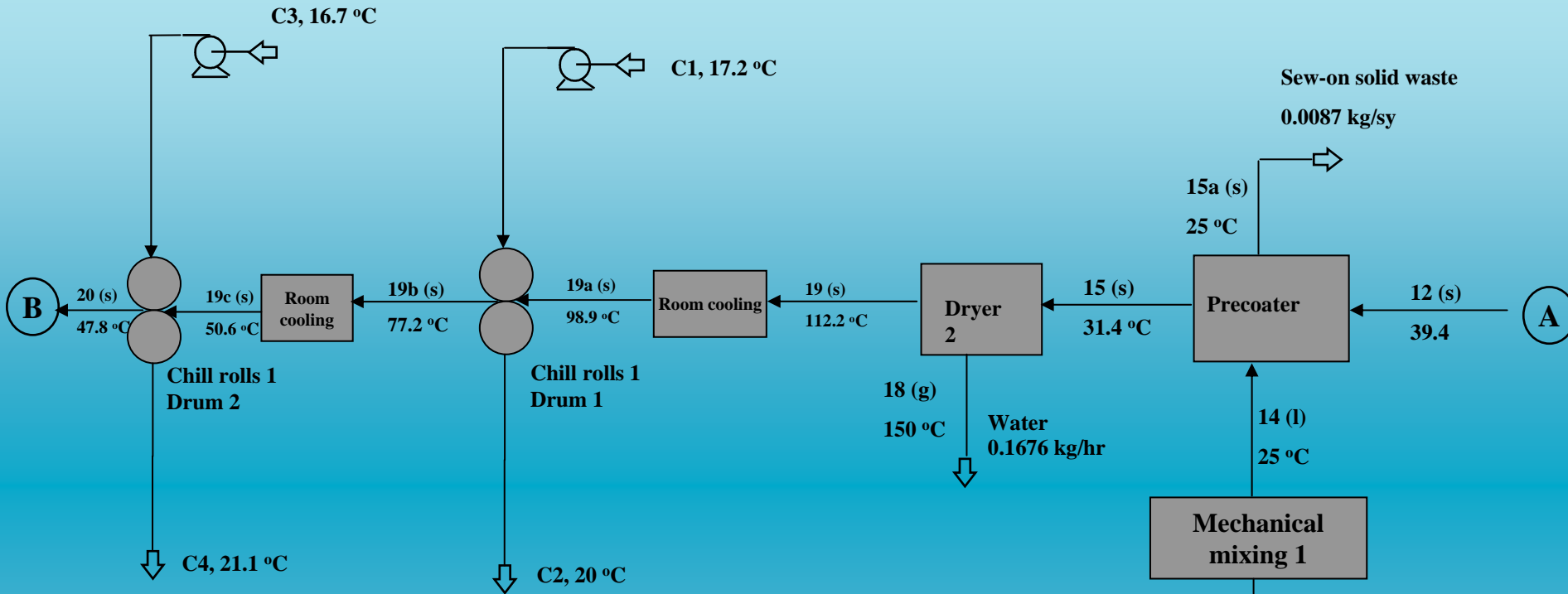

Latex breakdown	Material	Weight, kg/sy
Major component	Proprietary carboxylated butadiene/acrylate polymer	0.2220
	Aluminum trihydrate	0.3353
Additives	Additives	0.0039
	Total	0.5611

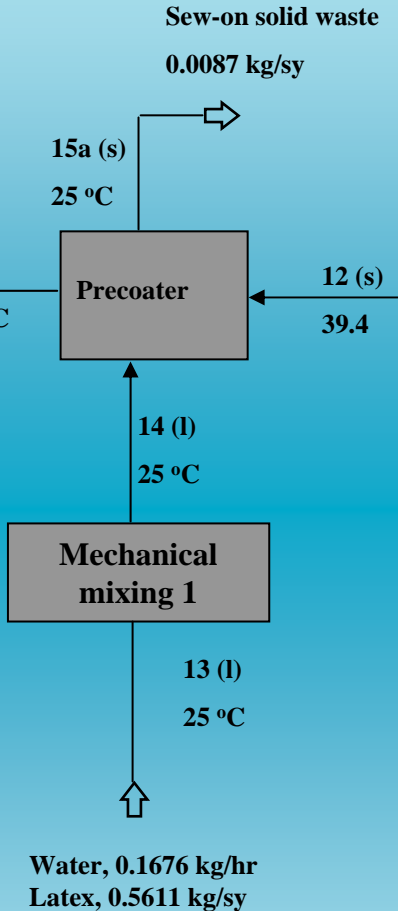

Detailed Process Flow Diagram of Polyolefin Tile Manufacturing Process- Page 3

	Total	
	Material	Dry Weight (kg/sy)
Major component	LDPE	0.3925
	fly ash	0.6215
	Post-consumer crushed glass	0.3598
	Hydrocarbon resin	0.1799
Additives	Additives	0.0820
	Total	1.6357

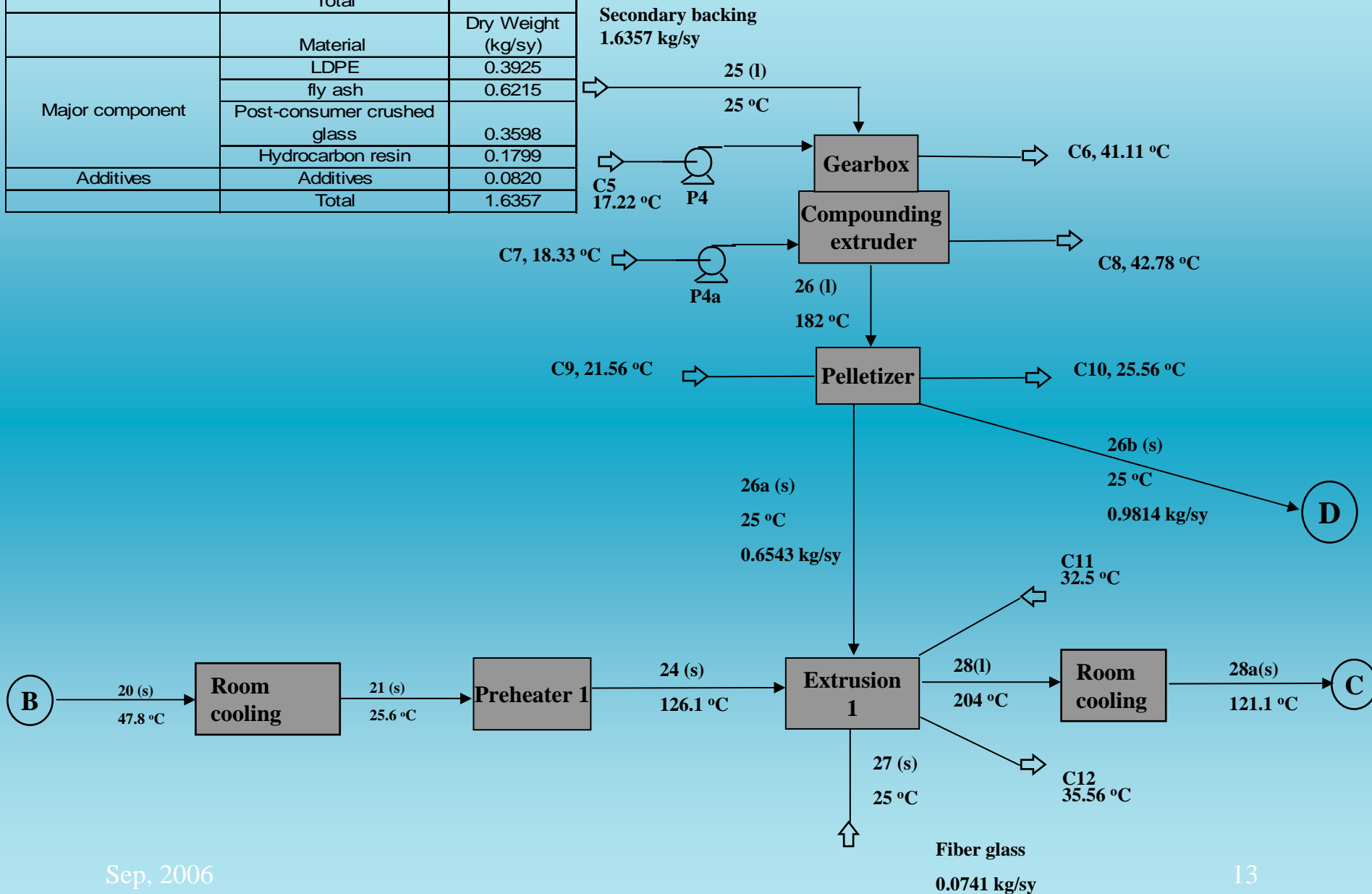

Detailed Process Flow Diagram of Polyolefin Tile Manufacturing Process- Page 4

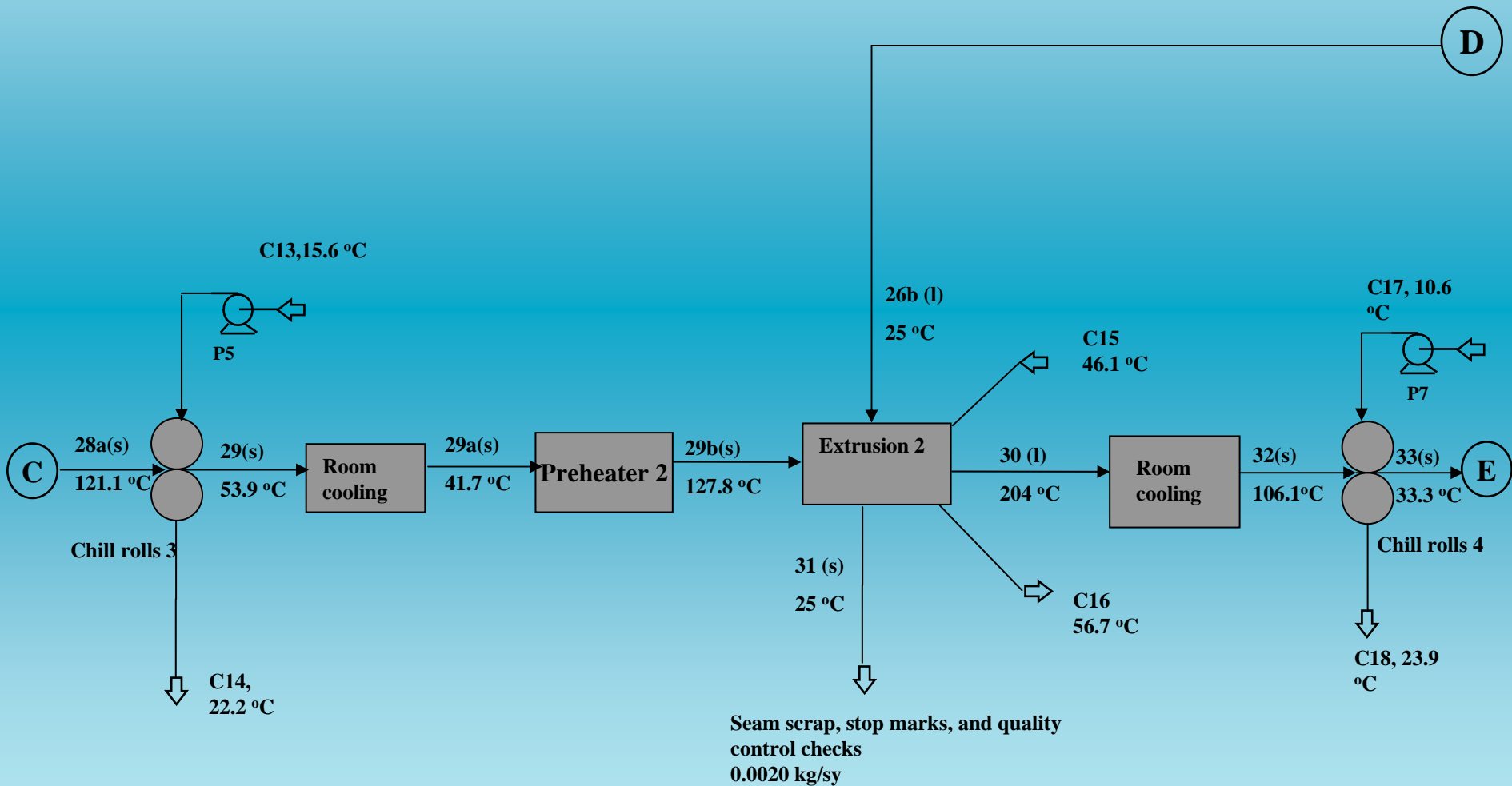

Detailed Process Flow Diagram of Polyolefin Tile Manufacturing Process- Page 5

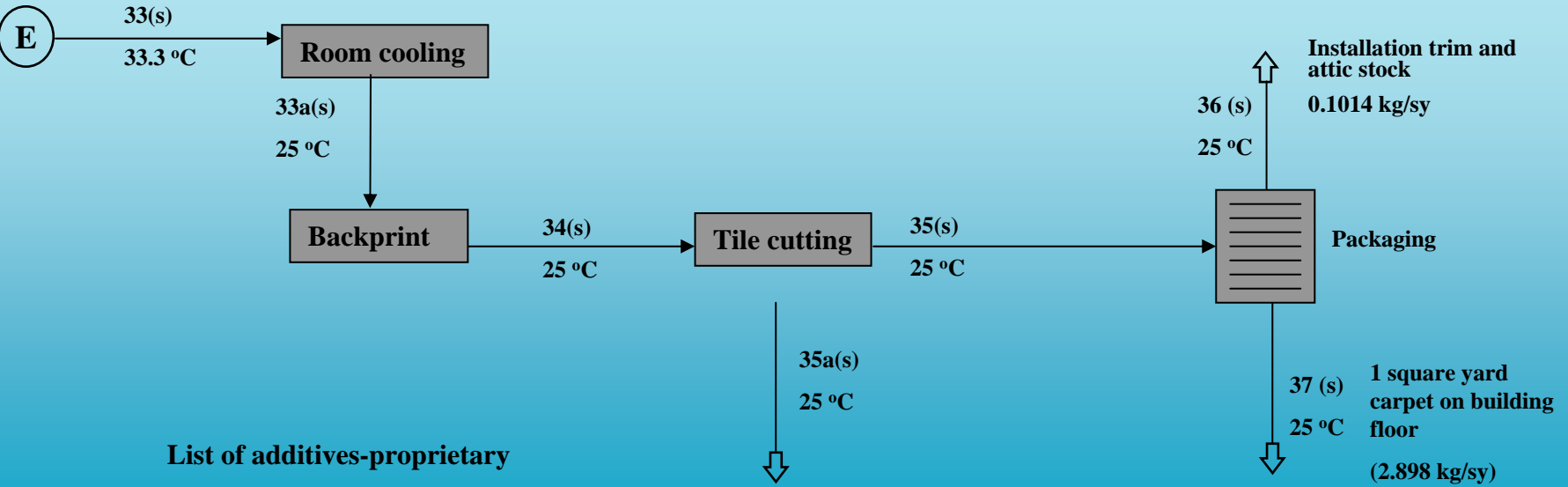

List of additives-proprietary

Chemical Name
Anionic Surface modifier
methylenebisthiocyanate
Anionic surfactant
2,5 Furadione modified ethylene/hexene-1 polymer
Maleic Anhydride/2,5-furadione
Parrafinic oil
Sodium Polyacrylate Thickener
Phenolic/Methacrylate Stainblocker
Chlorphenyl Ether
Fluorochemical

Window waste, seam scrap, warranty & inspection loss
0.1463 kg/sy

Carpet product composition

Materials name	Mass, kg/sy
Dyed nylon fiber	0.6847
PET core/nylon sheath	0.1131
Fiber glass	0.0682
LDPE	0.3614
Hydrocarbon resin	0.1656
Proprietary carboxylated butadiene/acrylate polymer	0.2031
Aluminum Trihydrate	0.3068
Fly ash	0.5722
Post-consumer crushed glass	0.3313
Additives	0.0915
Total	2.898

LCI of Carpet Manufacturing Processes – (I) Process Mass Input

Carpet composition	Chemical name	Mass of process input, kg/sy			
		PVC tile	Polyolefin tile	SBL broadloom	PU broadloom
Face fiber	Nylon fiber	0.63	0.81	0.86	0.84
Woven/nonwoven fabrics	PET	0.13	0.13		
	Fiber glass	0.04	0.07		
	Polypropylene			0.19	0.30
Backing polymeric system	PVC homopolymer	0.21			
	Ethylene-vinyl acetate copolymer	0.23			
	2-Ethylhexyl phthalate	0.56			
	poly (ethylacrylate-co-vinyl chloride)	0.37			
	LDPE		0.39		
	Hydrocarbon resin		0.18		
	Proprietary carboxylated butadiene/acrylate polymer		0.22		
	SB latex			0.22	
	Polyol				0.46
	MDI				0.22
	Ethylene glycol				0.06
Backing fillers	Calcium carbonate	1.97		0.51	0.54
	Fly ash		0.62		
	Glass cullet		0.36		
	Aluminum hydroxide		0.34	0.25	0.14
Additives	Additives	0.10	0.10	0.00	0.01
	Total	4.24	3.23	2.03	2.56

LCI of Carpet Manufacturing Processes – (II) Process Energy Consumption

Energy type	Energy consumption, kJ/sy				Comments
	PVC tile	Polyolefin tile	SBL broadloom	PU broadloom	
Electricity	1412	3923	675	647	
Dowtherm	0	0	0	0	
Heating steam	1589	1477	1380	871	85% efficiency has been included to determine how much steam is needed for
Direct fuel use in high temperature heating	3778	1612	4152	2540	
Cooling refrigeration	23	0	0	0	
Net energy	6802	7011	6206	4058	

LCI of Carpet Manufacturing Processes – (III) Process Emission

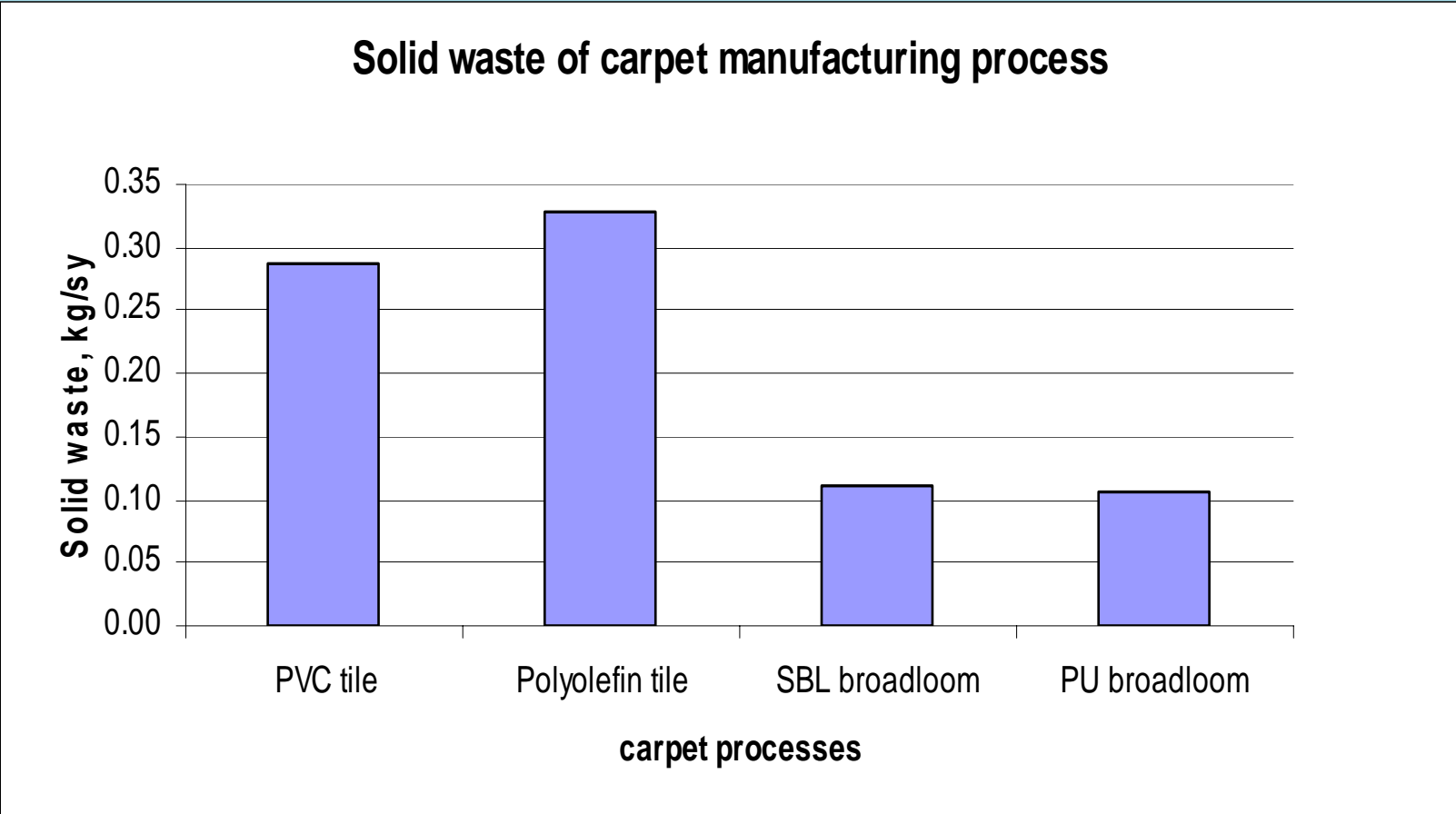

Carpet Supply Chain - Face Fiber

nylon6	Caprolactam	Ammonia	Natural gas	Natural gas (unprocessed)			
			Nitrogen from air	Air (untreated)			
			Oxygen from air	Air (untreated)			
			Water for rxn	Water (untreated)			
		Cyclohexanone oxime	Ammonia	Natural gas	Natural gas (unprocessed)		
				Nitrogen from air	Air (untreated)		
				Oxygen from air	Air (untreated)		
				Water for rxn	Water (untreated)		
			Cyclohexanone	Cyclohexane	Benzene	Naphtha	
					Hydrogen	Naphtha	
					Oxygen	Oxygen from air	
					Water for rxn	Water for rxn	
					Oxygen	Air (untreated)	
			Hydroxylammonium sulphate	Nitric oxide	Ammonia	Natural gas	
						Nitrogen from air	
						Oxygen from air	
						Water for rxn	
				Oxygen	Air (untreated)		
		Sulfuric acid		Sulfur trioxide	Oxygen from air	Oxygen from air	
					Sulfur	Sulfur	
				Water for rxn	Water for rxn		
			Water for rxn	Water (untreated)	Water (untreated)		
		Sulfur trioxide	Oxygen from air	Air (untreated)			
			Sulfur	Crude Oil			
			Water for rxn	Water (untreated)			
		Sulfuric acid	Sulfur trioxide	Oxygen from air	Air (untreated)		
				Sulfur	Crude Oil		
Water for rxn	Water (untreated)						
	Water for rxn		Water (untreated)				
Toluene	Naphtha	Crude Oil					

Mass Loss Tree-Polyolefin Tile

Carpet		Carpet composition	Unit	Advanced supply chain and commodity chemicals	Unit	Raw materials	Unit	
1 sy polyolefin carpet tile 2.898 n=10 0.113 0.327	kg/sy kg/kg kg/sy	Dyed nylon face fiber 0.807 n=4 0.070 0.057	kg/sy kg/kg kg/sy	Advanced supply chain chemicals	kg/sy kg/kg kg/sy	Natural gas Air Crude oil Water 1.521	kg/sy	
				1.783 n=8 0.337 0.601				
				Commodity chemicals				
				0.854 n=15 0.076 0.065				
				Advanced supply chain chemicals				
				0.797 n=13 0.618 0.493				
	Commodity chemicals							
	0.413 n=15 0.077 0.032							
	Woven/nonwoven backing fabrics 0.207 n=3 0.206 0.043	kg/sy kg/kg kg/sy	Advanced supply chain chemicals	kg/sy kg/kg kg/sy	Natural gas Air Crude oil Water Salt rock Sand Borax Bauxite ore Limestone 2.694	kg/sy	kg/sy	
								0.310 n=5 0.288 0.089
								Commodity chemicals
								0.749 n=7 0.097 0.082
Advanced supply chain chemicals								
0.000 n=0 0.000 0.000								
Commodity chemicals								
0.065 n=1 0.000 0.001								
Backing polymeric system 0.794 n=3 0.109 0.086	kg/sy kg/kg kg/sy	Advanced supply chain chemicals	kg/sy kg/kg kg/sy	Natural gas Air Crude oil Water 1.214	kg/sy	kg/sy		
							0.000 n=0 0.000 0.000	
							Commodity chemicals	
							0.065 n=1 0.000 0.001	
							Advanced supply chain chemicals	
							0.000 n=0 0.000 0.000	
Commodity chemicals								
0.065 n=1 0.000 0.001								
Backing fillers 1.317 n=3 0.294 0.388	kg/sy kg/kg kg/sy	Advanced supply chain chemicals	kg/sy kg/kg kg/sy	Fly ash Salt rock Water Bauxite Glass cullet 1.683	kg/sy	kg/sy		
							0.000 n=0 0.000 0.000	
							Commodity chemicals	
							0.065 n=1 0.000 0.001	
							Advanced supply chain chemicals	
							0.000 n=0 0.000 0.000	
Commodity chemicals								
0.065 n=1 0.000 0.001								

In each cell

First number is mass of chemical on the supply chain

Second number n=X, X is number of chemicals involved in the process that the cell represented.

Third number is the average mass loss of the process that the cell represented on a mass base

Fourth number is the average mass loss of the process that the cell represented based on per square yard carpet

Mass Loss Tree - PVC Tile

Carpet		Carpet composition	Unit	Advanced supply chain and commodity chemicals	Unit	Raw materials	Unit	
1 sy PVC carpet tile 4.000 n=10 0.072 0.288	kg/sy kg/kg kg/sy	Dyed nylon face fiber 0.645 n=4 0.070 0.045	kg/sy kg/kg kg/sy	Advanced supply chain chemicals	kg/sy kg/kg kg/sy	Natural gas Air Crude oil Water 1.216	kg/sy	
				1.426 n=18 0.337 0.481				
				Commodity chemicals				0.683 n=15 0.076 0.052
				Advanced supply chain chemicals				0.495 n=8 0.602 0.298
	kg/sy kg/kg kg/sy	Woven/nonwoven backing fabrics 0.174 n=2 0.213 0.037	kg/sy kg/kg kg/sy	Advanced supply chain chemicals	kg/sy kg/kg kg/sy	Air Crude oil Water Salt rock Sand Borax Bauxite ore Limestone 1.045	kg/sy	
				0.495 n=8 0.602 0.298				
				Commodity chemicals				0.375 n=12 0.083 0.031
				Advanced supply chain chemicals				0.853 n=4 0.713 0.608
	kg/sy kg/kg kg/sy	Backing polymeric system 1.318 n=3 0.105 0.138	kg/sy kg/kg kg/sy	Advanced supply chain chemicals	kg/sy kg/kg kg/sy	Natural gas Air Crude oil Water Salt rock Limestone 0.633	kg/sy	
				0.853 n=4 0.713 0.608				
				Commodity chemicals				3.750 n=12 0.097 0.364
				Advanced supply chain chemicals				0.000 n=0 0.000 0.000
kg/sy kg/kg kg/sy	Backing fillers 2.064 n=1 0.075 0.155	kg/sy kg/kg kg/sy	Advanced supply chain chemicals	kg/sy kg/kg kg/sy	Limestone 2.219	kg/sy		
			0.000 n=0 0.000 0.000					
			Commodity chemicals				0.000 n=0 0.000 0.000	
			Advanced supply chain chemicals				0.000 n=0 0.000 0.000	

In each cell

First number is mass of chemical on the supply chain

Second number n=X, X is number of chemicals involved in the process that the cell represented.

Third number is the average mass loss of the process that the cell represented on a mass base

Fourth number is the average mass loss of the process that the cell represented based on per square yard carpet

Mass Loss Tree – SBL Broadloom

Carpet		Carpet composition	Unit	Advanced supply chain and commodity chemicals	Unit	Raw materials	Unit	
1 sy SBL broadloom carpet 1.917 n=8 0.171 0.327	kg/sy kg/kg kg/sy	Dyed nylon face fiber 0.862 n=4 0.070 0.061	kg/sy kg/kg kg/sy	Advanced supply chain chemicals	kg/sy kg/kg kg/sy	Natural gas Air Crude oil Water 1.623	kg/sy	
				1.581 n=18 0.337 0.533				
				Commodity chemicals				0.913 n=15 0.076 0.069
				Advanced supply chain chemicals				0.000 n=0 0.000 0.000
	Woven/nonwoven backing fabrics 0.187 n=1 0.051 0.010	kg/sy kg/kg kg/sy	Advanced supply chain chemicals	kg/sy kg/kg kg/sy	Crude oil 0.201	kg/sy		
							0.000 n=0 0.000 0.000	
							Commodity chemicals	0.193 n=1 0.010 0.002
							Advanced supply chain chemicals	0.000 n=0 0.000 0.000
	Backing polymeric system 0.217 n=1 0.029 0.006	kg/sy kg/kg kg/sy	Advanced supply chain chemicals	kg/sy kg/kg kg/sy	Crude oil 0.443	kg/sy		
							0.000 n=0 0.000 0.000	
							Commodity chemicals	0.511 n=5 0.097 0.027
							Advanced supply chain chemicals	0.000 n=0 0.000 0.000
Backing fillers 0.760 n=2 0.437 0.333	kg/sy kg/kg kg/sy	Advanced supply chain chemicals	kg/sy kg/kg kg/sy	Salt rock Water Bauxite 1.077	kg/sy			
						0.000 n=0 0.000 0.000		
						Commodity chemicals	0.049 n=1 0.012 0.001	
						Advanced supply chain chemicals	0.000 n=0 0.000 0.000	

In each cell

First number is mass of chemical on the supply chain

Second number n=X, X is number of chemicals involved in the process that the cell represented.

Third number is the average mass loss of the process that the cell represented on a mass base

Fourth number is the average mass loss of the process that the cell represented based on per square yard carpet

Mass Loss Tree – PU Broadloom

Carpet		Carpet composition	Unit	Advanced supply chain and commodity chemicals	Unit	Raw materials	Unit	
1 sy PU broadloom carpet 2.412 n=10 0.063 0.152	kg/sy	Dyed nylon face fiber 0.835 n=4	kg/sy	Advanced supply chain chemicals 1.581 n=18	kg/sy	Natural gas Air Crude oil Water 1.573	kg/sy	
				0.337				kg/kg
	kg/kg	0.070	kg/kg	0.517	kg/sy	Commodity chemicals 0.913 n=15	kg/sy	
				0.076				
	kg/sy	0.059	kg/sy	0.067	kg/sy	Advanced supply chain chemicals 0.000 n=0	kg/sy	Crude oil 0.318
				0.000				
			Woven/nonwoven backing fabrics 0.296 n=1	kg/sy	0.000	kg/sy		
					0.051			
			0.015	kg/sy	0.000	kg/sy		
					0.000			
			Backing polymeric system 0.746 n=3	kg/sy	0.306 n=1	kg/sy	Crude oil Natural gas Water Salt rock Air 1.930	kg/sy
					0.010			
		0.059	kg/sy	0.003	kg/sy			
				0.003				kg/kg
		Backing fillers 0.682 n=2	kg/sy	2.256 n=18	kg/sy	Salt rock Water Bauxite 0.874	kg/sy	
				0.458				kg/kg
		0.295	kg/kg	1.033	kg/sy			
				1.033				kg/sy
		0.201	kg/sy	0.000 n=0	kg/sy			
				0.000				kg/kg
		0.201	kg/sy	0.000	kg/sy			
				0.000				kg/kg
			kg/sy	0.027 n=1	kg/sy			
				0.012				kg/kg
			kg/sy	0.000	kg/sy			
				0.000				kg/kg

In each cell

First number is mass of chemical on the supply chain

Second number n=X, X is number of chemicals involved in the process that the cell represented.

Third number is the average mass loss of the process that the cell represented on a mass base

Fourth number is the average mass loss of the process that the cell represented based on per square yard carpet

Energy comparison of carpet products

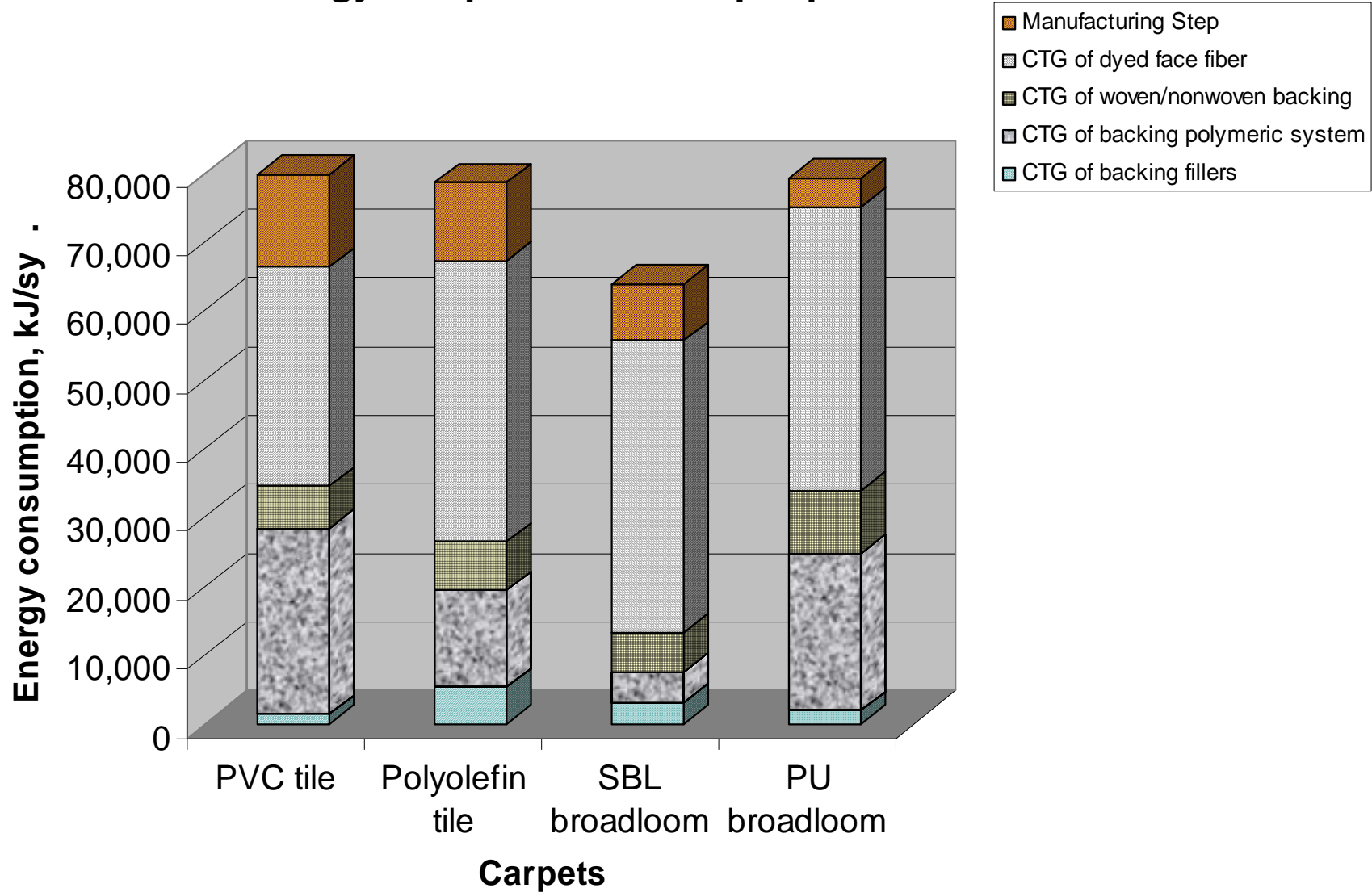

Conclusion

- **The manufacturing plant of PU broadloom carpet consumes the least amount of energy among four carpets, but all four carpets have similar amount of energy consumption from a cradle-to-gate(CTG) life cycle point of view.**
- **Face fiber contributes a significant amount of energy consumption in the life cycle of all four carpets, which makes recycling of carpet product more meaningful if face fiber can be reused.**

Future Work

- **LCI of carpet use phase and recycle phase.**
- **Incorporate the use phase and recycling phase of carpet products to analyze the cradle-to-grave life cycle of carpet products.**

Acknowledgement

- **Georgia Tech. Univ.**
- **Shaw Industry**