

Resource Use Management

Non-Traditional Tools
for LCA and
Sustainability

Introduction

- LCA is Not Complicated Enough!
 - ◆ Non-Chemical Impacts
 - ◆ Cumulative Impacts
 - ◆ Sustainability
- Non-Traditional Approach

Working Definition of Non-Chemical Impacts

- Artificial* physical or biological occurrences that are detrimental to human health or the ecosystem ***for generations to come.***

*Made or influenced by human activity

To address the sustainability issue

Traditional Categories

- Resource Depletion
 - ◆ Biotic
 - ◆ Abiotic
- Land Use/Transformation
 - ◆ Human Use
 - ◆ Ecosystem, landscape degradation
 - ◆ Habitat alteration, fragmentation

Examples of EIA Categories

- Air Particulates
- Water Flow Variation
- Thermal Pollution
- Soil Stability
- Land Use Patterns
- Effects of Sound
- Economics
- Resources
- Aesthetics

Impact Framework

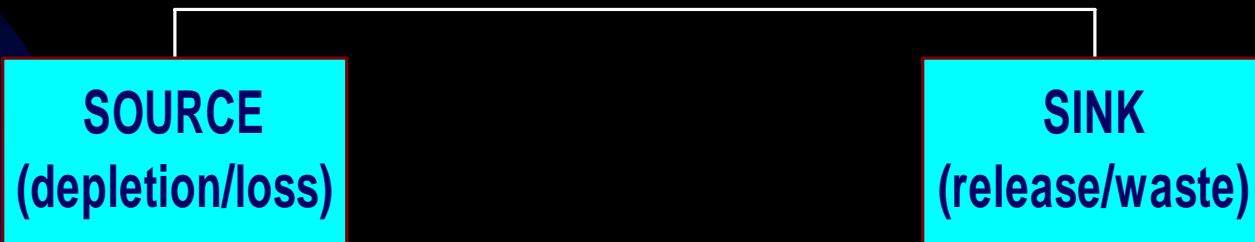

Animal

- species
- habitat
- diversity

Vegetable

- deforest
- NPP
- species
- wetlands
- diversity

Mineral

- fossil fuels
- fresh water
- groundwater
- minerals
- soil
- land

Physical

- heat
- radiation
- noise
- dirt
- solid waste
- infrastructure

Chemical

Biological

- non-indig sp
- genetic engr
- pathogens
- population
- bio wastes

GEMS

- Geographic Environmental Management System
- NASA Langley
- GIS-based
- Site-specific
- NOT THE WAY TO GO!

DIAS

- Dynamic Information Architecture System
- DOE Argonne National Lab
- Object-oriented way to structure any problem

Traditional model-to-model interaction approach

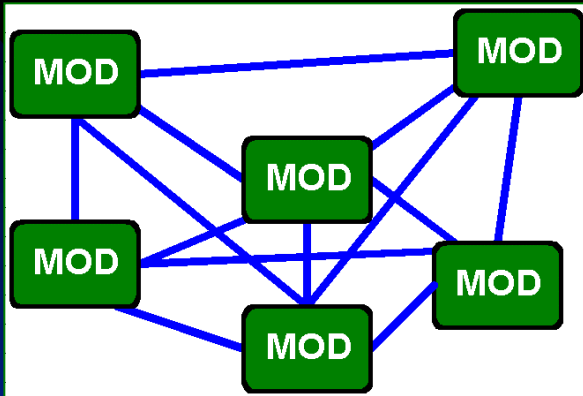

DIAS object-model interactions

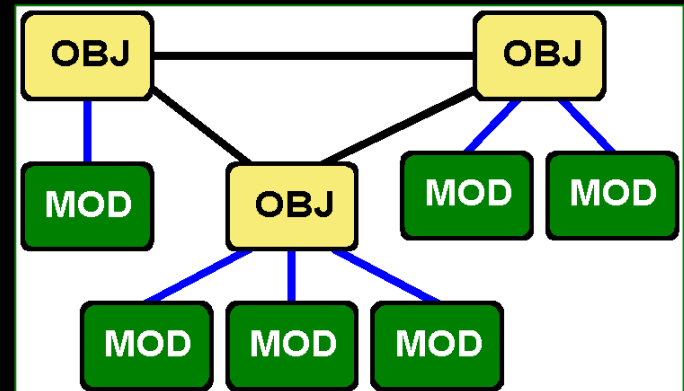

Entity Object

A discipline-specific object representing “**real-world**” entities

- Attributes (State) - properties of an object
- Aspects (Behavior) - how an object acts and reacts

Environmental Taxonomy

- Natural
 - ◆ Region
 - ◆ Non-Human Life Form
- Artificial
 - ◆ Tangible objects built by humans
- Phenomenon
 - ◆ Biological, Meteorological, Geological, Sociological, Astronomical, Hydrological
- Conceptual

Natural Environment

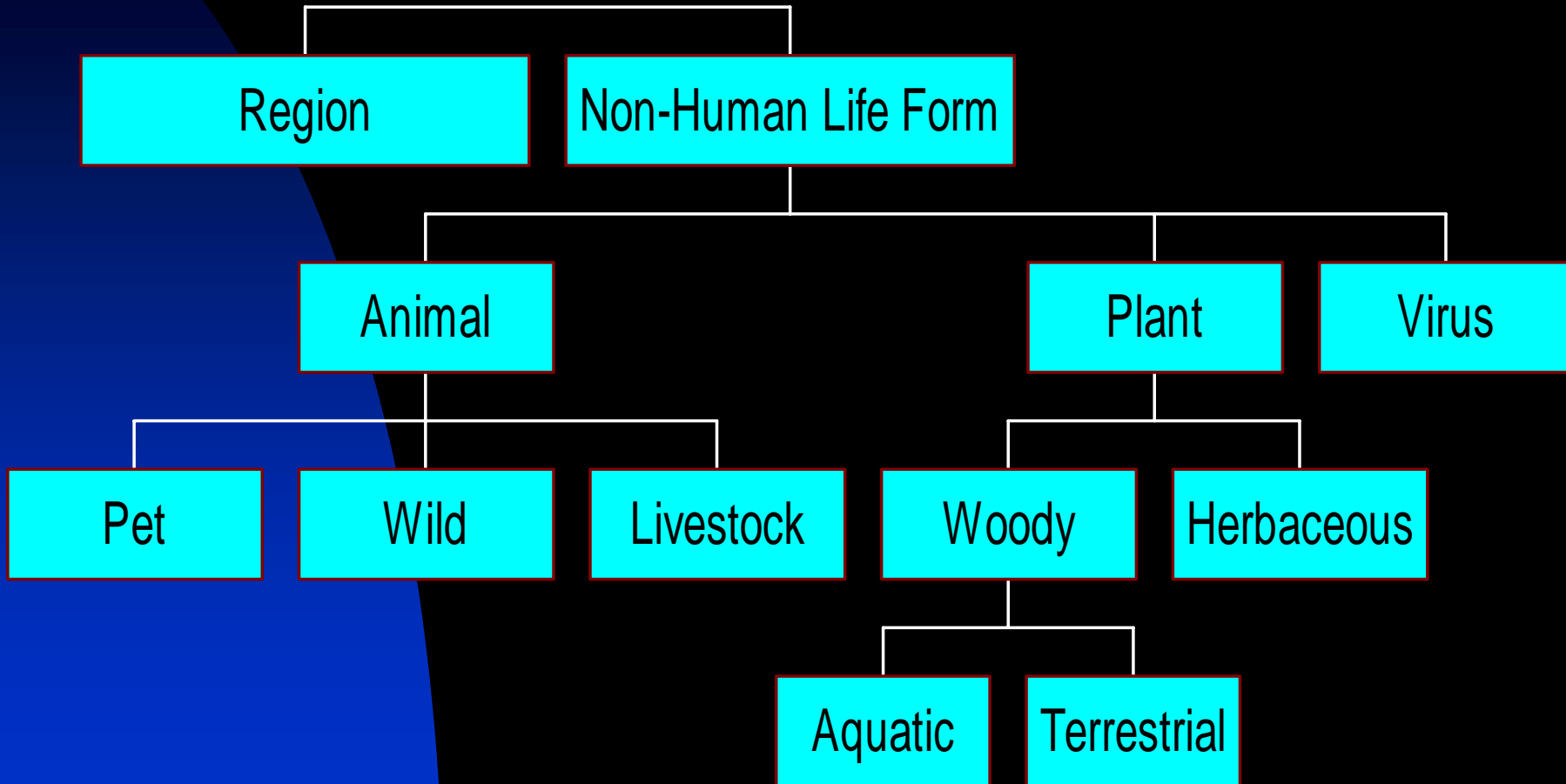

Artificial Environment

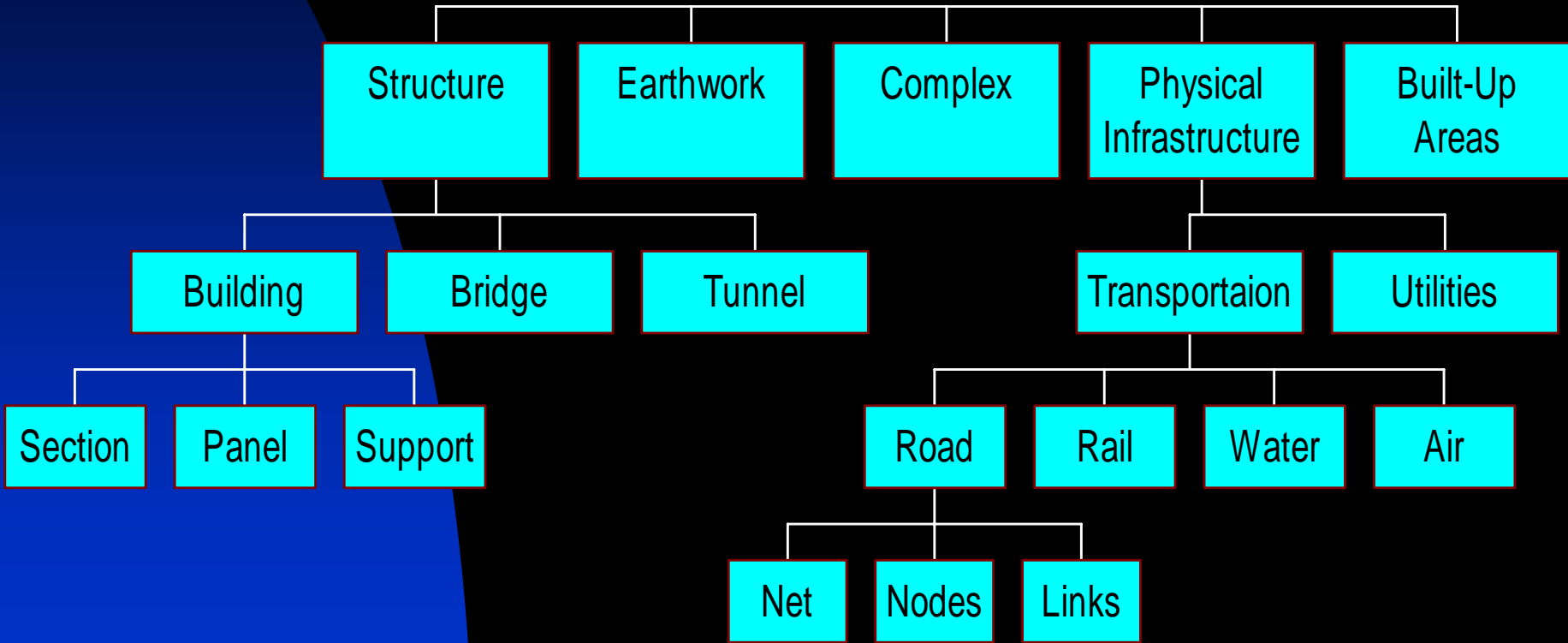

Phenomenon Environment

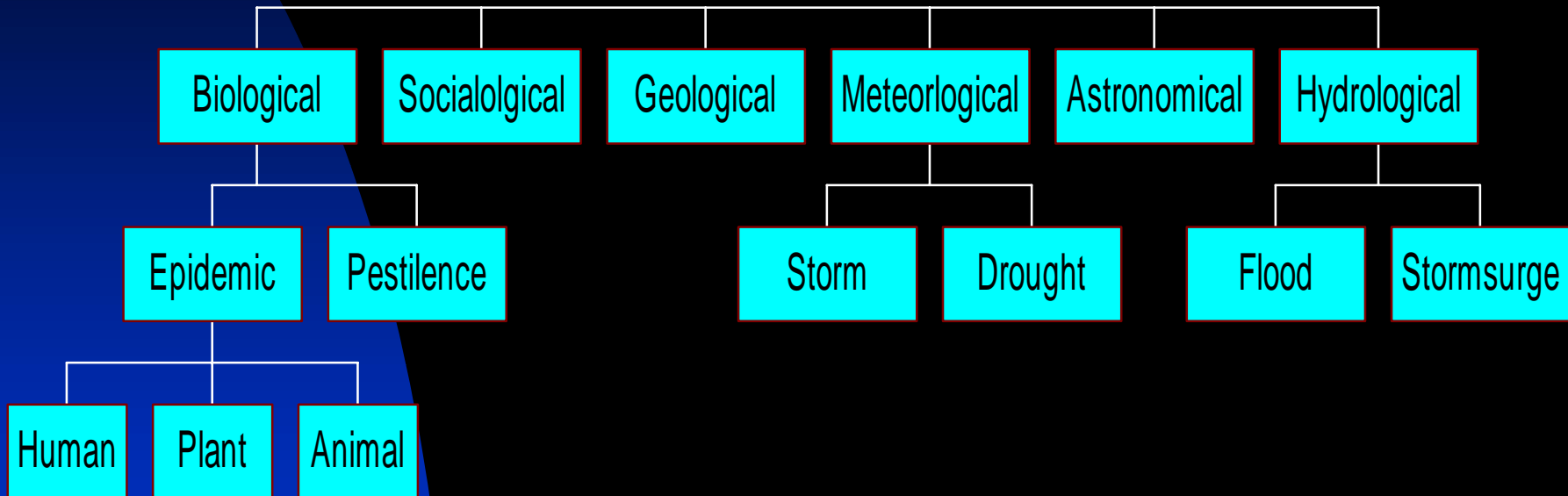

Life Cycle Assessment

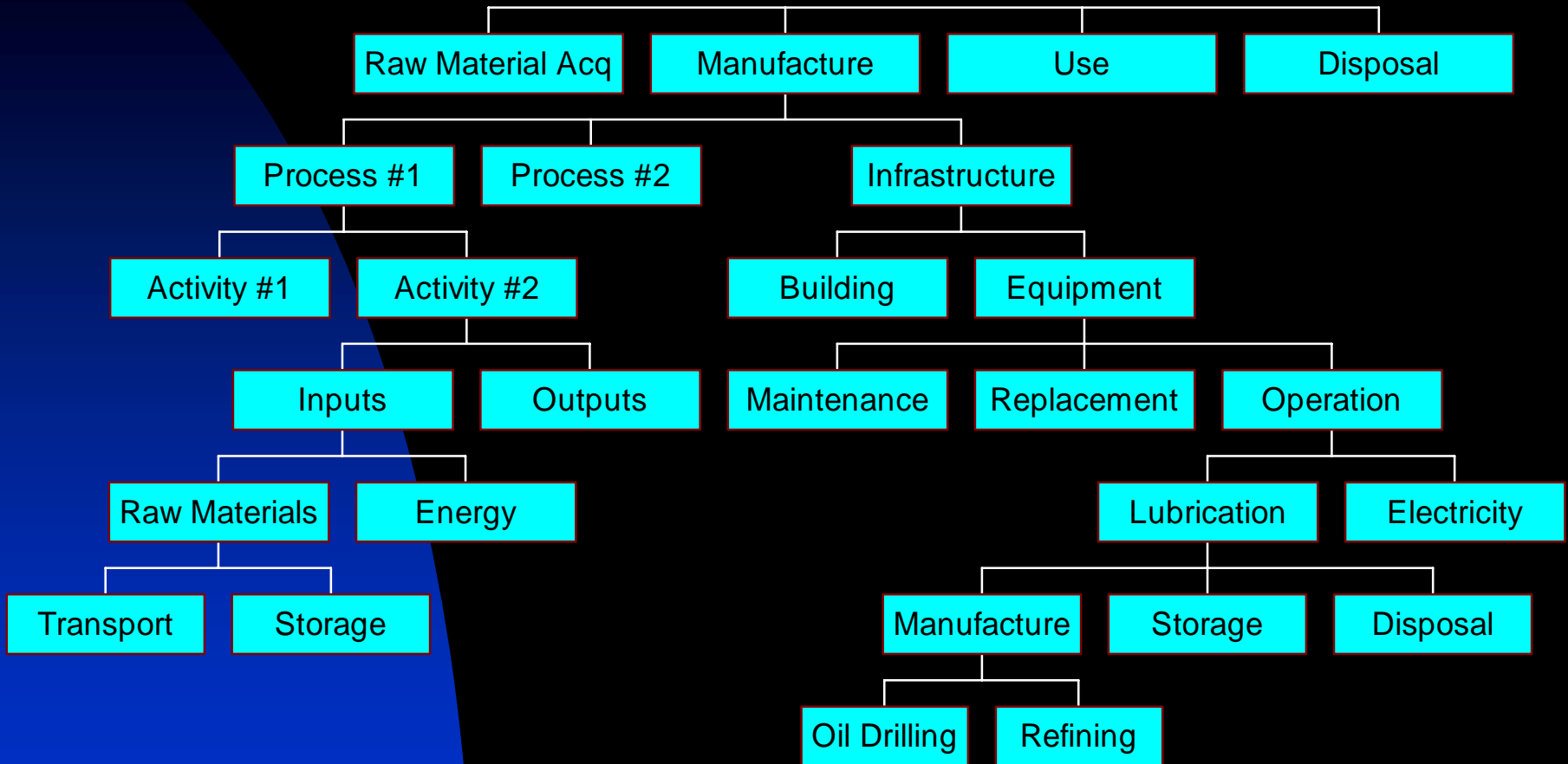

DIAS DESIGN

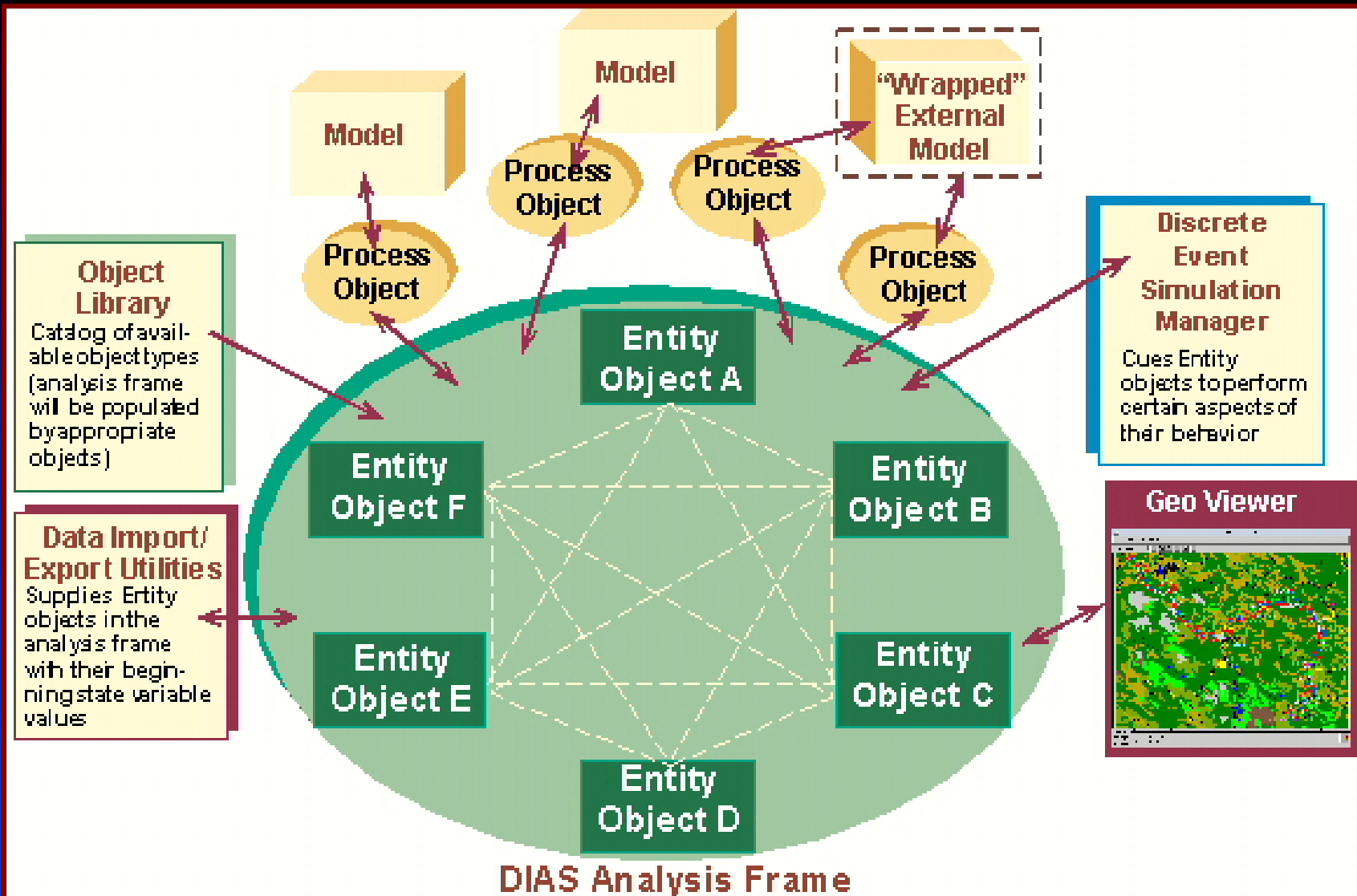

Next Steps

- Flesh Out Non-Chemical Impact Framework
 - ◆ Workshop
 - ★ Impact Categories
 - ★ Impact Assessment Methodologies
 - ★ Indicators
- Apply DIAS to Framework
- Evaluate for use in LCA and Sustainability

Conclusions

- Are we asking the right questions?
- Increase focus on non-chemical impacts
- Base LCA on DIAS architecture
- Build object libraries to simplify
- Consider cumulative impacts and sustainability

Terri Hoagland

U.S. EPA

National Risk Management Research Lab

26 W Martin Luther King Drive

Cincinnati, OH 45268

Ph: 513-569-7783

Fax: 513-569-7111

hoagland.theresa@epa.gov